

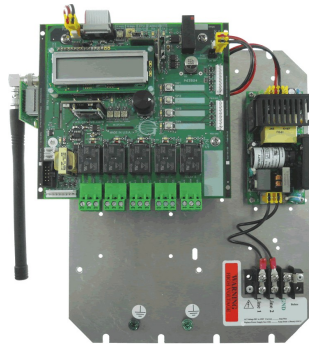

# RXC-3000

USB / Twist-n-Touch™

## Receiver Decoder Controller Hardware Manual



Genave / NRC, Inc.  
24234 Chesley Trail  
Hampton, MN 55031  
651-460-6616 Telephone 651-460-6686 Fax

[www.genave.com](http://www.genave.com)  
[support@genave.com](mailto:support@genave.com)  
Copyright 2010. Genave / NRC, Inc.

Tech. Publication No. 9000-0000-040 Rev 03



## **Warning**



If incorrectly used, this equipment can cause severe injury. Those who use and maintain the equipment should be trained in its proper use, warned of its dangers, and should read the manuals before attempting to set up, operate, adjust or service the equipment. Keep this manual for future reference.

# **Important Safety Information**

## **System Planning**

Proper planning is the cornerstone to an effective warning system. The Federal Emergency Management Agency (FEMA) publishes the “Outdoor Warning Guide” CPG 1-17, which should be used in planning your system. In addition, you should recognize and understand the following items:

- Outdoor warnings sirens and equipment are not intended to be heard indoors. Conversely indoor devices are not intended to cover outdoor environments. All devices have specific purposes and distances that they can be considered effective. Proper placement and selection of the correct equipment is necessary to cover a desired area. Refer to the FEMA guide for placement guidelines.
- Training is necessary to ensure those responsible can correctly activate the system. It is also necessary that everyone understand the purpose of the warning system and the protective actions they need to take when the system is activated. Periodic tests can serve to accomplish the training for the operators, in addition to demonstrating the various signals to the public.
- All warning systems must have contingency plans in case equipment problems or operator errors interfere with its performance. Just as with the primary warning system, the contingency plans should be periodically tested to make sure those responsible know how to implement them and the necessary response from the public is achieved.

# Important Safety Information

## Installation & Service Precautions



•Electrocution, severe personal injury and damage to equipment can occur during installation or servicing this equipment. All electrical work should be performed by, or under the supervision of an experienced electrician and in accordance with all applicable electrical, fire, building and safety codes.



•This equipment can start at any time from local controls, automatic timers, radio remote, commands from a computer and many other sources. The sound output can cause hearing damage, while other attached equipment can cause personal injury when they engage. Whenever working in or around the equipment you must assume it could activate at any moment, and take appropriate precautions to protect yourself and others. You should completely disable the equipment before working on or in close proximity to any part of it.

•You must test the system and equipment to insure it is operating correctly after the installation, as well as after any work has been performed.

## System Operation

•Training is necessary to ensure those responsible can correctly activate the system. It is also necessary that everyone understand the purpose of the siren and the protective actions they need to take when the system is activated. Periodic tests can serve to accomplish the training for the operators, in addition to demonstrating the various signals to the public.

•You must carefully read and completely understand all the information about the system including its abilities and its limitations. Since no warning system is infallible, you must have contingency plans for warning, in the event the primary systems do not perform as expected, for any reason.

©2010, Genave/NRC, Inc.

## **RXC-3000™ Hardware**

Phone 651-460-6616

Fax 651-460-6686

### **PRINTED IN USA**

The contents of this manual are the property of Genave/NRC, Inc. and are copyrighted. Any reproduction in whole or in part is strictly prohibited. For additional copies of this manual or software, please contact Genave/NRC, Inc.

### **Warranty:**

**Genave/NRC, Inc. products are warranted to be free from defects in material and workmanship for a period of ONE (1) year from the date of shipment. Genave, during this period, will repair or replace any parts, which upon our examination appear to be defective in materials or workmanship. This warranty does not apply to defects, malfunctions or breakage due to improper installation, servicing, handling or use thereof, nor to units that have been damaged by lightening or other “Acts of God”, excess current, reversed supply connection, nor to units that have had their serial numbers altered or removed. Equipment damaged in Acts of War, abuse, misuse, tampering, submersion or willful destruction will also void this warranty.**

**Prior to returning equipment for warranty repair, contact the Genave Customer Service Department for an RMA number. They can be reached by using the telephone number or fax number listed above. Genave/NRC, Inc. (Genave) and its licensors offer this warranty in lieu of any and all other guarantees or warranties, either express or implied, including without limitation the implied warranties of merchantability and fitness for a particular purpose, regarding hardware or software. Genave and its licensors do not warrant, guarantee or make any representations regarding the use or the results of the use of the software or hardware in terms of its correctness, accuracy, reliability, most recent or otherwise. You assume the entire risk as to the results and performance. The exclusion of implied warranties is not permitted by some jurisdictions. The above exclusion may not apply to you.**

In no event will Genave, its licensors, directors, officers, employees or agents (collectively Genave's licensor) be liable to you for any consequential, incidental or indirect damages (including damages for loss of business profits, business interruption, loss of business information, and the like) arising out of the use or inability to use the software or hardware even if the Genave and/or its licensor has been advised of the possibility of such damages. Because some jurisdictions do not allow the exclusion or limitation of liability for consequential or incidental damages, the above limitations may not apply to you. Genave and its licensors liability to you for actual damages from any cause whatsoever, and regardless of the form of the action (whether in contract, tort, (including negligence), product liability or otherwise), are expressly excluded.

Genave reserves the right to make changes in specifications at anytime and without notice. The information furnished by Genave is believed to be accurate and reliable, however, no responsibility is assumed by Genave for its use, nor infringements of patents or other rights of third parties resulting from its use. No license is granted under any patents or patent rights of Genave/NRC, Inc., its licensors or suppliers.

### **Life Support Policy:**

**Genave/NRC, Inc. products are not authorized for use as critical components in life support devices or systems without the express written approval of the president of Genave/NRC, Inc. As used herein:**

**1) Life support devices or systems are devices or systems which, (a) are intended for surgical implants into the body, or (b) support or sustain life, or whose failure to perform, when properly used in accordance with instructions, can reasonably be expected to result in a significant injury to the user.**

**2) Critical component is any component of a life support device or system whose failure to perform can be reasonably expected to cause the failure of the life support device or system, or to affect its safety or effectiveness.**

CSP, Communications Signal Processor, Genave Operating System, GOS, CSP-105, CSP-107, CSP-108, CSP-120, RXC-3000 and RXCPro are Trademarks of Genave/NRC, Inc. The Genave name and logo are Registered trademarks of Genave/NRC, Inc. Touch-Tone is a Registered trademark of American Telephone and Telegraph.

Other names used in this manual are trademarks of their respective companies.

# RXC-3000 Receiver Decoder Controller

## Table of Contents

- Overview.....8**
  - How It Works.....8
  - Building Blocks.....9
  - Menus And What They Mean.....10
- Installing.....12**
  - Mounting the RXC-3000.....12
  - AC Wiring.....13
    - Power Connection .....13
  - DC Wiring.....14
  - Solar / Battery Wiring.....14
  - Attachment To A Pole.....14
  - Attaching Speaker.....15
- Programming.....16**
  - Installing ComstarG3.....16
  - USB Port, Connector And Cable.....17
  - Passwords.....17
  - Restoring RXC-3000 to Default Programming.....17
- Inputs.....18**
  - Input Header Characteristics (J14 and J15).....18
  - Triggering RXC-300 Off Of an Input.....19
  - (Example) Interfacing RXC-3000 To External Switches.....20
- Outputs.....21**
  - Relay Characteristics.....21
  - Output Header Pinout (Aux Output).....22
  - Output Header Transistor Characteristics.....22
  - (Example) Connecting RXC-3000 To Heavy Loads.....23
- PA Audio Port.....24**
  - Pinout And Characteristics Of External Amplifier Control Port.....24
  - Pinout And Characteristics Of 600 Ohm Audio Port.....25
  - Setting PA Port Levels.....26
- Radio Port.....27**
  - Radio Port Pinout.....27
  - Radio Power Port .....27
  - Setting Rx Audio Levels.....28
  - Setting Tx Audio Levels.....28

Radio Audio Levels to PA Port.....29

How To Change Frequency (Maxon Radio Only).....29

How To Change DCS/CTCSS (Maxon Radio Only).....29

How To Set Wide/Narrow Bands (Maxon Radio Only).....29

How To Set Squelch (Maxon Radio Only).....29

Returning Radio To Default Settings (Maxon Radio Only).....29

**DTMF Decoder.....30**

DTMF Decoder Characteristics.....30

Triggering RXC-3000 Off Of A DTMF String.....30

How To Enter/Adjust DTMF Strings.....30

DTMF Learn Mode.....30

“Live Look” (DTMF Digit Grabber).....30

**Two Tone Sequential Decoder.....31**

Two Tone Decoder Characteristics.....31

Triggering RXC-3000 Off Of A Two Tone Signal.....33

How To Enter/Adjust Two Tone Signal Strings.....33

Two Tone Learn Mode.....33

“Live Look” (Two Tone Grabber).....33

**Real Time Clock.....34**

Triggering RXC-3000 From The Real Time Clock.....34

How To Adjust Time.....34

How To Set Daylight Savings Dates.....34

Real Time Clock Battery.....34

**ADPCM Audio Player.....35**

How Songs Are Played To The PA Port.....35

How The RXC-3000 Knows What Songs To Play.....35

Creating ADPCM Files From .mp3, .wav, Etc.....35

TF Card (MicroSD) Characteristics.....36

How To Program The TF Card.....36

How To Put A Song Into A Trigger File.....36

**Misc.....36**

LCD Display Backlight.....36

Heartbeat LED.....36

Fuse.....36

**Specifications.....37**

General Specifications.....37

Page Intentionally Left Blank

## Overview

The RXC-3000 is a stand alone Receiver – Decoder – Controller (RXC) device that is fully programmable from either a computer or via the new Genave Twist-n-Touch rotary input switch. The unit is equipped with a transceiver, signal decoders, programmable logic controller, power supply, up to 5 relay outputs, optional LCD screen, board mounted activation switches and USB computer interface, all contained in a NEMA 4 weatherproof enclosure.

Since the RXC-3000 is programmable, it is not dependent upon any manufacturers particular tone code scheme. It can, of course, detect and generate Motorola, GE, Bramco, RCA and many other standard codes. But it can just as easily be programmed to use custom tone codes already in use, or to develop your own code schemes for a particular application.

## How It Works

The RXC-3000 listens to audio from its radio receiver for either DTMF or Two Tone Sequential signals. When the unit receives signals that it has been programmed to listen for, it starts the associated pre-programmed script from its memory. The script controls which outputs are activated and how long they are to operate, if a sound, song or voice message is played from the ADPCM player, if the audio from the player is sent to its Public Address (PA) port, etc...

### How the History Memory works

The RXC-3000 remembers each signal that it has been taught to receive and logs it into its memory. If the unit is equipped with the optional Real Time Clock (RTC) each history entry will also have the time and date of the received signal.

### How the Real Time Clock works

The Real Time Clock (RTC) enables the RXC-3000 to start a script at a certain time and date. It can also disable scripts from running, aka “Lockouts” (e.g. keep siren from operating at night) at certain times of the day or on a particular day of the week such as Saturday or Sunday. The RTC has a battery that keeps the time current in the event power is lost.

### How the Radio works

When the RXC-3000 is equipped with a Maxon transceiver, all of the settings for the Maxon can be made directly through the RXC-3000. No special programs or cables are required to make changes to the radio's settings. Alternatively, the RXC-3000 can be connected to any audio source or radio receiver chosen by the installer. The radio receives signals on a single narrow or wide band signal and sends the audio to the RXC-3000 decoder circuitry. The radio's audio can also be sent to the PA audio port by the RXC-3000.

### How the Audio Player works

If the RXC-3000 is equipped with the optional ADPCM player, the unit can play any song, sound or voice message that is stored in its TransFlash (TF) card. The audio is sent to the PA port and 600 Ohm port. The RXC-3000 can play up to 100 different audio files that are stored on the TF card.

### How the Inputs work

In addition to the Twist-n-Touch switch, the RXC-3000 has 4 switches that can be programmed to start or stop any script in the unit's memory. Additional inputs are available for installers to connect to their own external switches.

**How the Outputs work**

The RXC-3000 comes equipped with 5 Single Pole Single Throw (SPST) high power relays. Additionally, the RXC-3000 has an output header where the installer can tap into the transistors that control the relays as well as 3 additional transistors that are open for special use. During the running of a script, a command in the script will tell an output to turn on and/or off. Scripts can have timers embedded in them which allow relays to cycle on and off continuously for a predetermined amount of time (e.g. wail signal for 3 minutes).

**How the Audio Port works**

The RXC-3000 can control an external amplifier. Not only does it send audio out this port, but it has control points in the port to power up and enable several different types of amplifiers. Two pins in the port are connected to the 600 ohm transformer which allows audio from the ADPCM or radio to be sent to the amplifiers.

**How the 600 Ohm port works**

The RXC-3000 can send radio or ADPCM audio through a balanced 600 Ohm audio transformer for use by installers when they need to interface the RXC-3000 to an external PA system.

*Building Blocks*

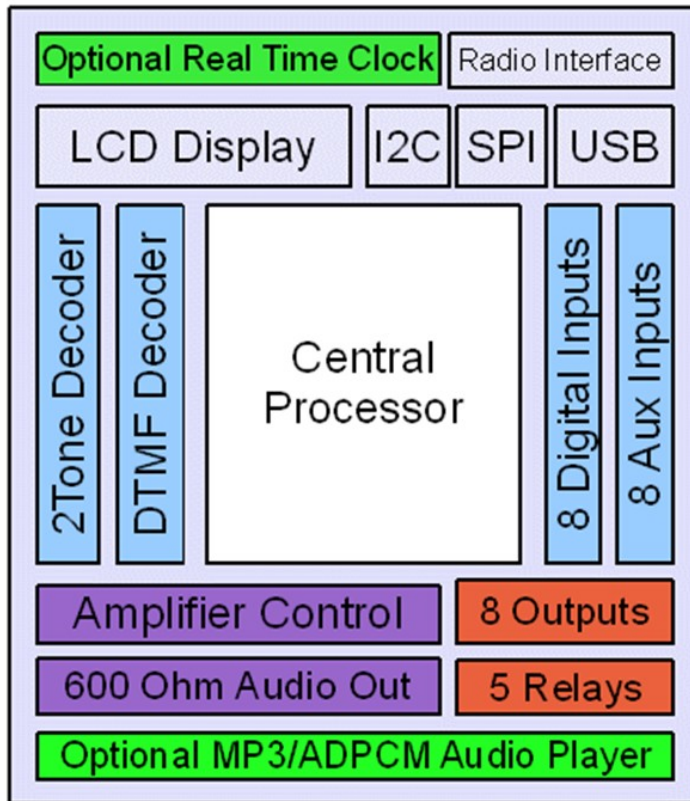

**Menus And What They Mean**

**RXC-3000 Main Screens**

PROGRAM NAME  
RXC3K-SIRENS.CG3

Displays the user program running in the RXC-3000.



System Grp Unit  
001 001 001

Displays the unit's settings for System, Group and Unit.



Current Time  
22:56 Nov 16th

Displays the current time and date when equipped with the Real Time Clock.



Last DTMF Decode  
13589\*1

Displays the last decoded DTMF signal received.



ACTION HISTORY \*  
345 Log Entries

Displays the number of log entries in the action history. (Max is 512)  
A double click of the "twist-n-touch" knob will allow you to go through the logs. (refer to Prog. Guide Sec. 10)



Receiver Freq  
154.415 W 131.8

Displays the receiver's frequency, Wide/Narrow band, and DCS/CTCSS code.



ADJUST SETTINGS\*  
(enter optional Password if asked)

A double click of the "twist-n-touch" knob will allow entry into the settings menus.

Note: Sub-menu screens will time out in 3 minutes and return the RXC-3000 to normal operation without Twist-n-Touch knob movement.  
LIVE DTMF\* and LIVE TTS PAGING\* do not time out.

## "Adjust Settings" Screens

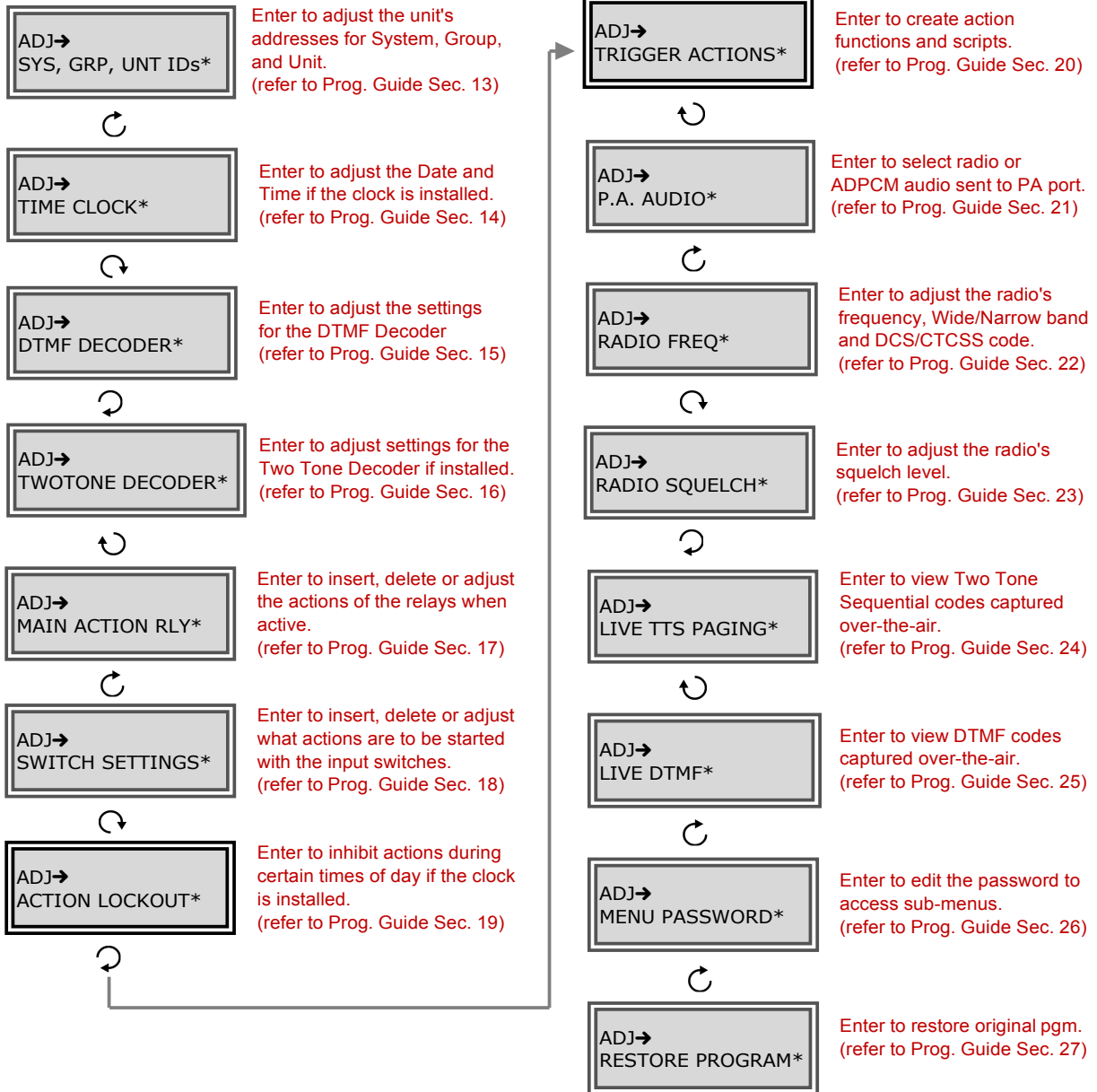

## Installing

### *Mounting the RXC-3000*

The enclosure is made of polycarbonate and has a NEMA 4X rating when shipped from the factory. Four mounting inserts are provided on the back of the enclosure for mounting the box to a wall. The inserts are threaded for metric M5 bolts. Mounting feet are available for the enclosure (Genave P/N 7050-0000-019). The feet allow front-on mounting of the enclosure to a wall and can be mounted vertically, 45 degrees, or horizontally. If you are mounting the equipment to a pole it is important to keep the enclosure flat and not allow the box to twist. The door gasket will not completely seal if there is a twist to the box. If you need design assistance please contact Genave©. We have several options available for pole mounting.

When making connections to the enclosure, do not drill through the top or sides of the box. Make all connections through the bottom of the enclosure to maintain at least a **NEMA 3R** rating.



The internal equipment is mounted to a metal backplane. The backplane is secured to the enclosure with screws that are specifically designed for plastics. Do not use any other type of screw to secure the backplane to the enclosure, as it will damage the standoff.

AC Wiring



**Power Connection**

The RXC-3000 requires 90 to 250 volts AC power to operate. The unit is supplied with a 3 position barrier terminal block. The terminal screw size is #6 screw and will accept a forked terminal with a maximum width of .320". Terminal #3 is grounded to the backplane. This terminal should be bonded/grounded to earth ground.

**AC Connections:**

**110 Volt :**

- Connect Hot wire to "Line 1"
- Connect Neutral wire to "Line 2"
- Connect Earth Ground wire to "GND"

**220 Volt:**

- Connect Line 1 to "Line 1"
- Connect Line 2 to "Line 2"
- Connect Earth Ground wire to "GND"

240 VAC single phase wiring

120 VAC single phase wiring

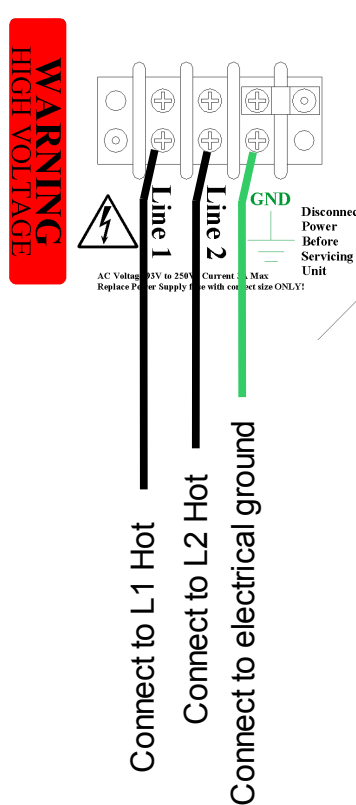
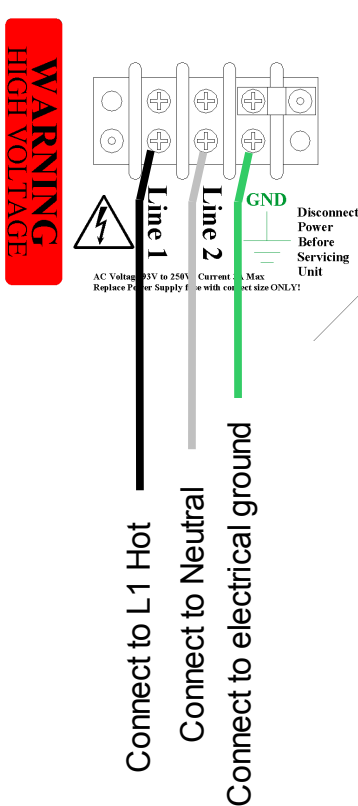

208/240 VAC 3 phase wiring

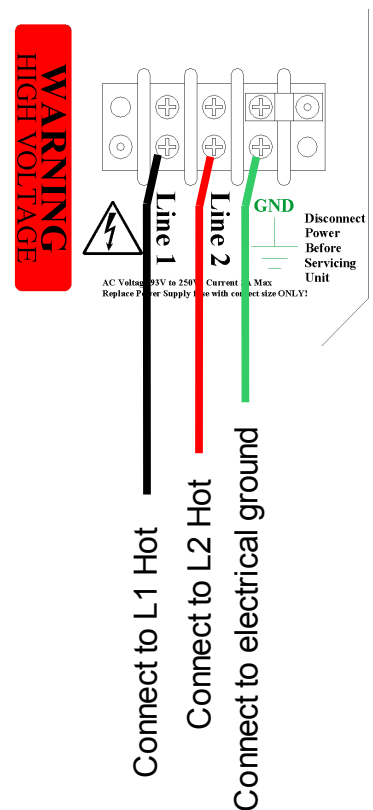

### *DC Wiring*

The installer can choose to power the RXC-3000 from a +12 Volts DC power source that can supply a minimum of 3 amps. The connector type is a Tyco 3-640427-2 IDC connector. It has a pin spacing of 0.156 inches and is made for 20 AWG wire. A special tool is required to make connections. Alternatively, Genave can make a custom length cable for installation.

**Warning:** Make certain that the polarity of the wires is correct. Even though the unit has diode protection for reverse voltages, damage to the RXC-3000 may occur if the polarity is reversed.



### *Solar / Battery Wiring*

The RXC-3000 can be powered by a solar panel, charger and battery housed in a single enclosure that mounts to a pole or wall. The wires leading from the solar cabinet to the RXC-3000 are landed on the same terminal block normally used for the AC power. However, the terminals will be marked as “DC Only”. The installer will need to make certain that the polarity of the wires matches the labelling of the terminals. Reversing the polarity may damage parts of the RXC-3000.

### *Attachment To A Pole*

Genave offers a pole mounting kit (HWS-5051) for the RXC-3000. The kit can be used to attach the RXC-3000 to a wood pole with screws, or it can be attached to a steel pole with the supplied stainless steel banding.

### Attaching Speaker

When ordered with the 70 watt amplifier (P/N OPT-70WAMP), one or two speakers can be attached to the RXC-3000. One can be directly attached to the bottom with a special reinforcing plate from Genave or two can be supplied up to 40 feet away from the unit. The speakers are connected to the 70 watt amplifier via connectors J2 and J3).

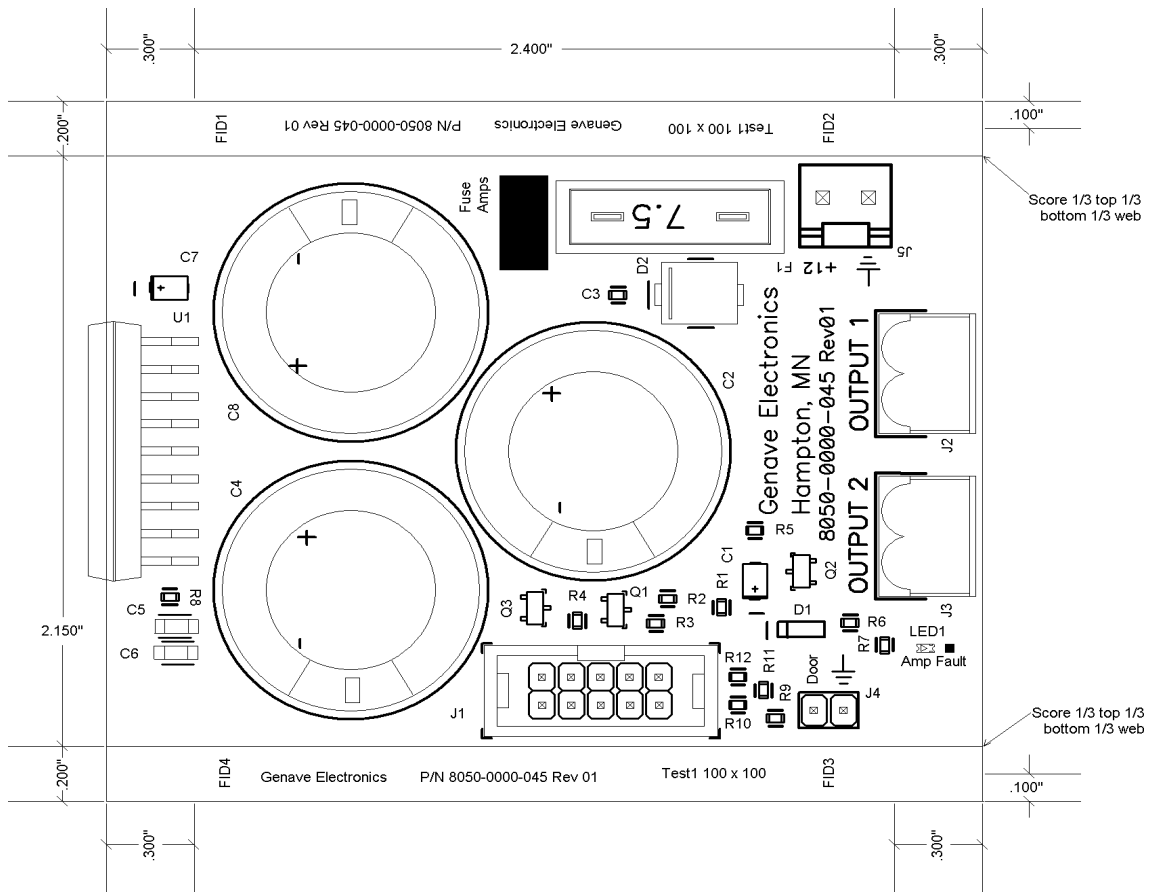

Illustration 1: 70 Watt Amplifier

## Programming

### *Installing ComstarG3*

The RXC-300 can be programmed with a computer running the ComStarG3 program. The program can either be downloaded from the Genave.com website or it can be supplied on a thumbdrive. To install the program on a computer, follow these instructions:

#### **Thumbdrive Installation to Computer Disk drive.**

- 1) Insert the thumbdrive into your computer. The computer should automatically find the drive and install it as a removable disk drive.
- 2) If the program does not automatically install, you may need to use Windows Explorer to select the drive and manually start the installation program: **setup.exe**

The program will create and install to the directory **C:\Program Files\Genave**

The program will also install all of the files you need into the Genave directory.

The program will also ask if you want a desktop icon.

The first time you install ComStarG3 on your computer, select the option to install the USB Drivers.

- 3) Attach your USB cable to the RXC unit and run **ComStarG3.EXE**.

- 4) The first time your run ComstarG3, click **Edit->Preferences** and select the USB drive.

The file that holds all of the configuration data for your Genave product will automatically load when you start the ComstarG3 program. If you make changes to the file, use "SAVE AS" and save the new file to the hard drive. It is best if you also save the file to the thumbdrive. This will be your backup copy of the changes.

**KEEP YOUR THUMBDRIVE SAFE.** If you need to return your Genave product for service, you will need to send us the thumbdrive along with the unit if you have made changes to the data files in the field. This will be our only way of knowing what the unit has been programmed to do.

### ***USB Port, Connector And Cable***

The RXC-3000 communicates with a computer over a USB 2.0 port. The port's connection is a mini type B 5 pin USB receptacle. The maximum USB cable length is 16 feet.

#### **Belkin cable F3U138-0 “6 foot USB Type A to mini 5 pin Type B”.**

Radio Shack P/N 55011001

Walmart P/N F3U138-0

Best Buy P/N 9463109



### ***Passwords***

The 5 character password locks out access to the sub menus.

*Please refer to the Programming Guide 9000-0000-041 for more information*

### ***Restoring RXC-3000 to Default Programming***

If during changes or setup, you need to return the RXC-3000 to a previous program, the RXC-3000 holds the last program downloaded to the unit through the USB in its memory.

**Warning!!! Restoring the running program to its original program sent with the unit will delete all previous changes to the running program.**

*Please refer to the Programming Guide 9000-0000-041 for more information*

# Inputs

## Input Header Characteristics (J14 and J15)

The inputs for the RXC-3000 are ALWAYS pulled low to pin 9 of J14 or J15. You can connect these inputs to switches or opto-couplers. We recommend that they are not connected directly to a digital level source unless there is protection between the two circuits.

Never supply voltage to these inputs. Even though they are protected with diodes in case a voltage above +5VDC is applied to them, they may become damaged. Each input has a pull up resistor.

Input header J14 is used to add additional remote switches to the RXC-3000.

Input header J15 is for future use with sensors designed for the RXC-3000. Do not use these inputs.

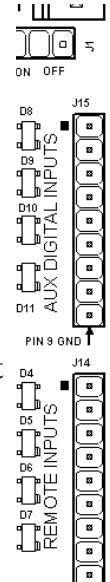

Genave Electronics P/N 8000-000-041 Rev 01

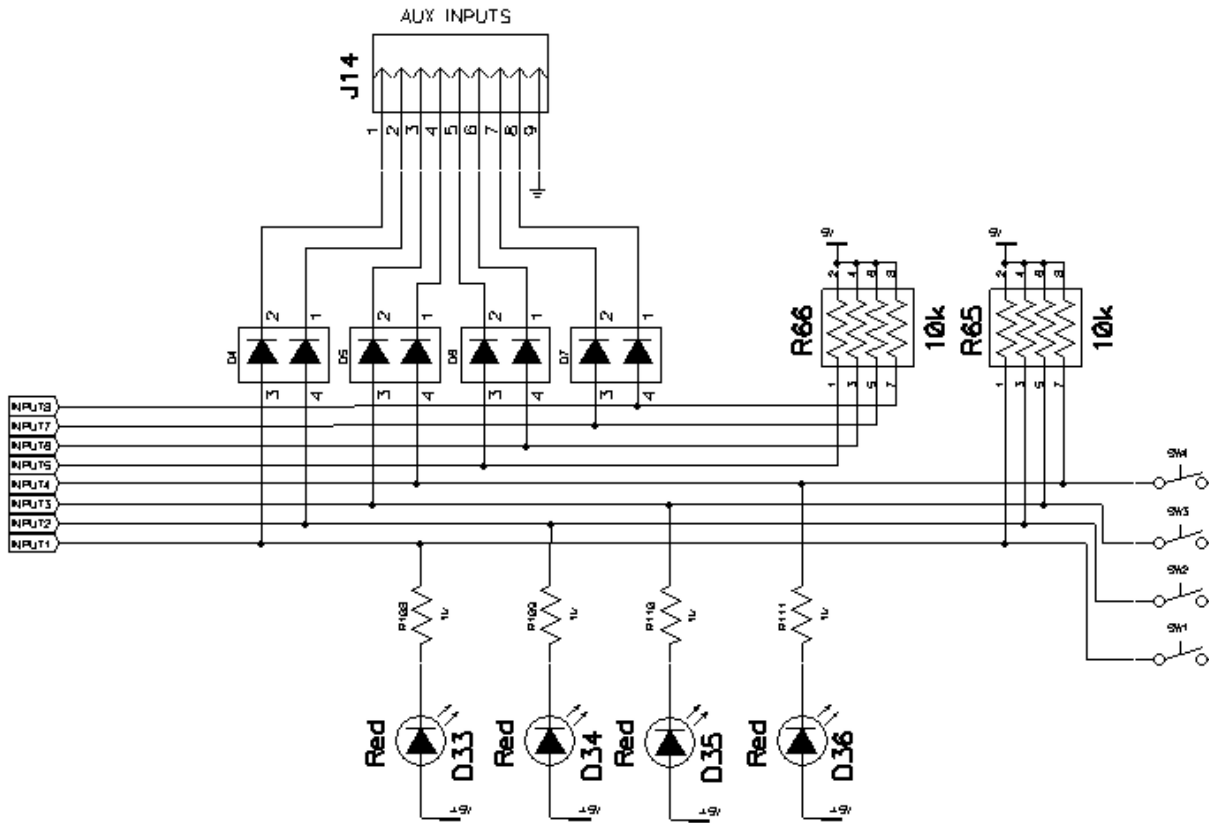

### *Triggering RXC-300 Off Of an Input*

The following items describe input triggering:

- (1) Each of the 8 inputs can start an action script, but only one script per switch.
- (2) The action scripts need to be setup before a switch can be attached to them.
- (3) The name of the action script will appear on the screen as you make your selections.
- (4) The action script begins upon the closure of the switch. If the switch is still closed when the action is complete, it will not trigger again until the switch is opened and then closed again.
- (5) Each input has a 150 millisecond debounce. If the switch closure is faster than the debounce, no actions will start.

*Please refer to the Programming Guide 9000-0000-041 for more information*

(Example) Interfacing RXC-3000 To External Switches



Example wiring method from input header to user switches with the RXC-3000

RXC-3000

Turn off ALL power before working on any electrical equipment. Follow all applicable electrical and safety rules and regulations. This is only an example. Your contactor and wiring may differ. Electrical work should only be performed by licensed and qualified personnel.

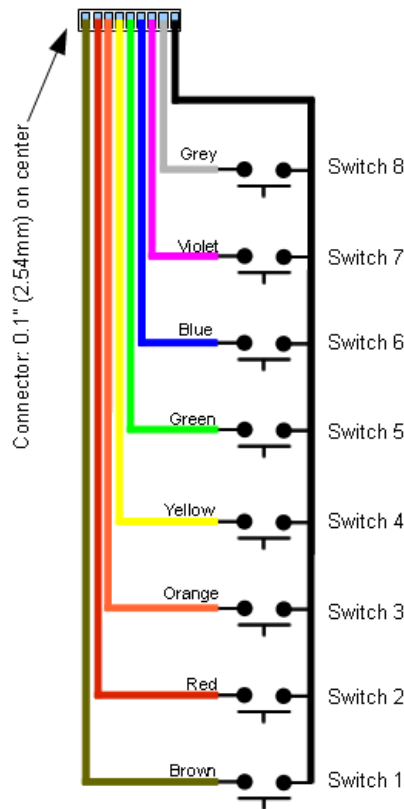
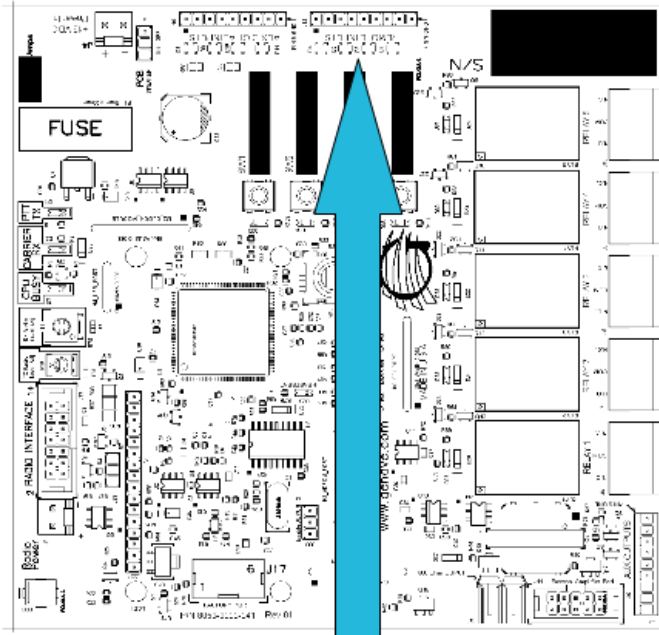

In this example, remote switches are used to control the RXC-3000. The switches shown are momentary contact (press and release).

Notes:

- (1) Use dry contact closure switches or opto-isolated switches only.
- (2) Use the ground reference (PIN 9) from the RXC-3000 as the common for the switches. NEVER CONNECT THE SWITCHES TO ANY OTHER VOLTAGE OR GROUND SOURCE OTHER THAN PIN 9 OF THE INPUT HEADER. YOU MIGHT DESTROY THE RXC-3000.
- (3) keep the wires as short as possible.

# Outputs

## Relay Characteristics

The RXC-3000 has 5 high power relays available for use. Each relay can handle 240VAC at 7 Amps. Each relay's outputs are directly connected to a 3 position header (J6 to J10) that can accept wires up to 12 AWG diameter.

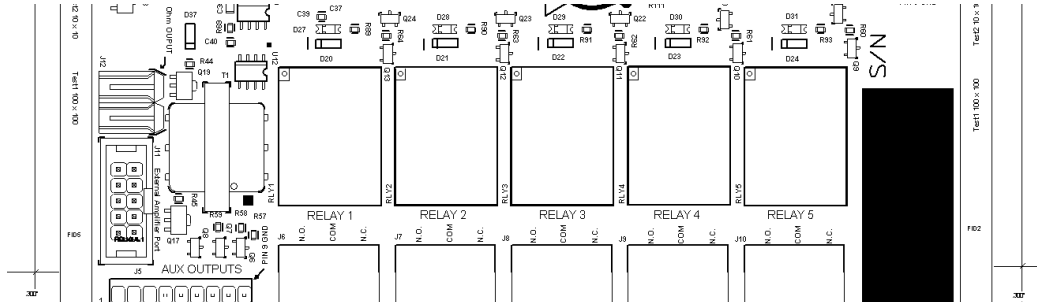

Each output connector is a 1FormC output (A single switch with normally open, common and normally closed connections).

The relay is supplied on one side of its coil with +12VDC and the other side of the coil controlled by a transistor that, when active, pulls the relay's coil to ground and activates the relay.

The transistors that control the relays are also connected to the output header along with 3 uncommitted transistors. (see below).

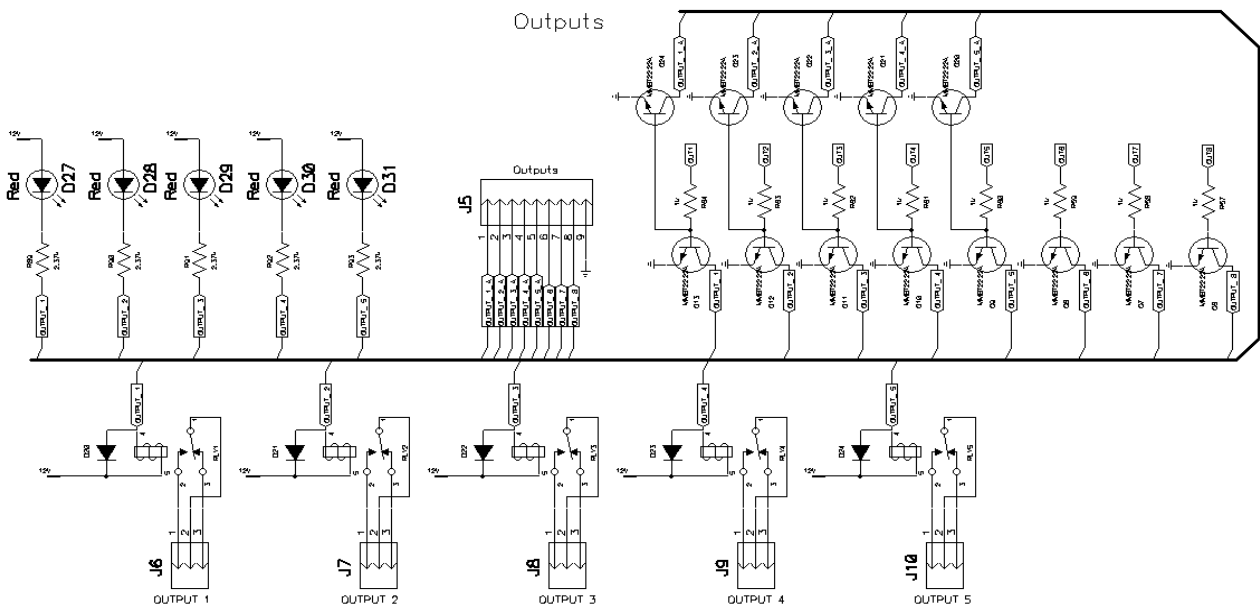

### *Output Header Pinout (Aux Output)*

The first 5 pins of the Aux output header are connected to the 5 on board relays. When they are off, the outputs will be +12VDC. When the transistors are on, the output will be 0 VDC. Do not connect these pins to any voltage higher than +12VDC since the voltage will go through the relays and into the RXC-3000's power supply.

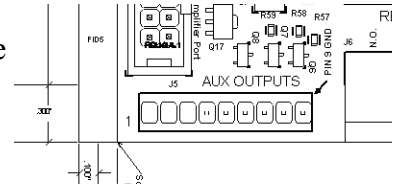

### *Output Header Transistor Characteristics*

Pins 6,7,8 are connected to the collectors of 3 uncommitted transistors. Each transistor can handle a maximum of 30VDC and 150mA. When activated, the transistors pull the pins to ground (pin 9).

*(Example) Connecting RXC-3000 To Heavy Loads*

**Example wiring method to control heavy loads with the RXC-3000**



RXC-3000

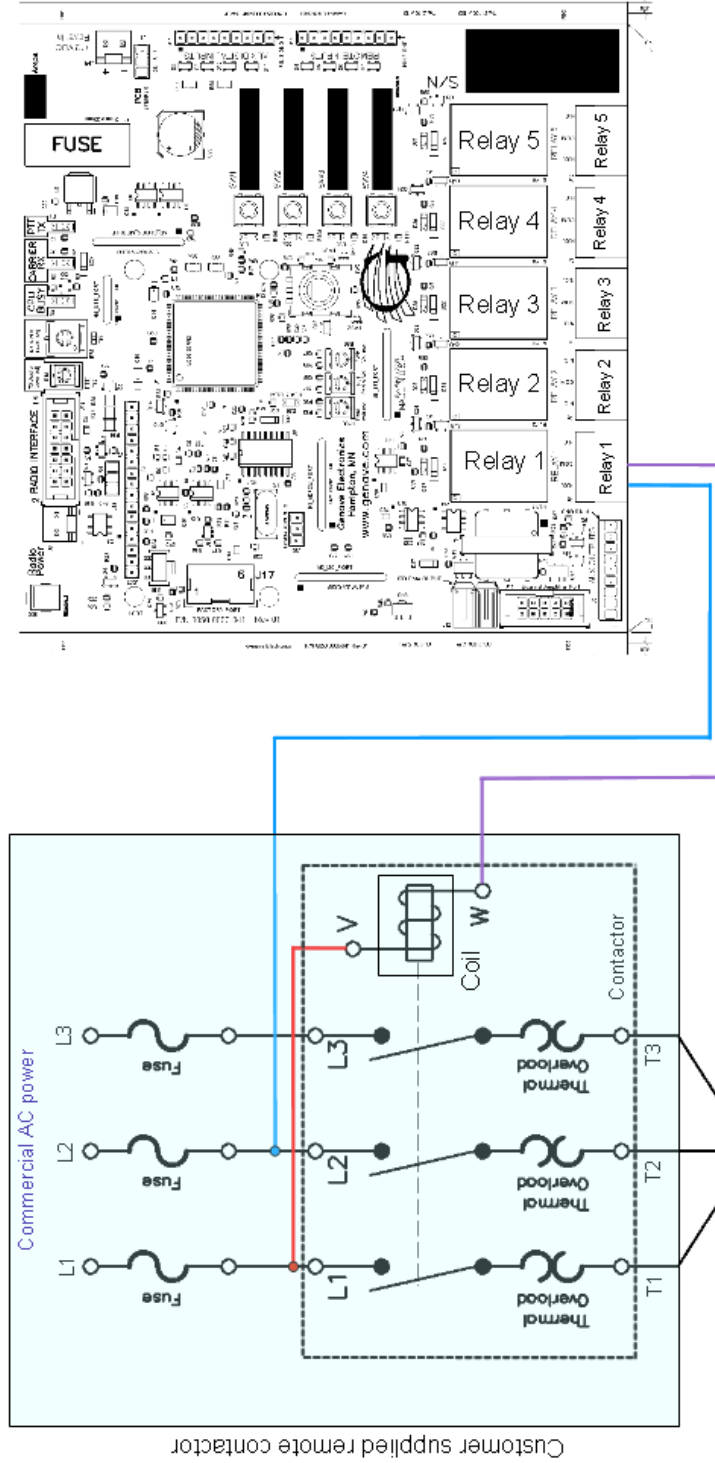

Customer's motor, light, resistive or inductive load

**In this example, when relay #1 on the RXC processes the radio command to engage, it completes the coil circuit of the contactor. The contactor then turns on and lets the voltage flow to the customer's device.**

Turn off ALL power before working on any electrical equipment.  
 Follow all applicable electrical and safety rules and regulations.  
 This is only an example. Your contactor and wiring may differ.  
 Electrical work should only be performed by licensed and qualified personnel.

## PA Audio Port

### Pinout And Characteristics Of External Amplifier Control Port

The amplifier control port “PA Port” is specifically designed to control an external amplifier for the audio that comes out of the RXC-3000. The pinout of the connector is:

Pin 1	600 Ohm Audio 1	Pin 6	Amp Diagnostics Input
Pin 2	600 Ohm Audio 2	Pin 7	Ground
Pin 3	External Amp Power Up	Pin 8	Not Used
Pin 4	External Amp Mute	Pin 9	Ground
Pin 5	External Amp Enable	Pin 10	Not Used

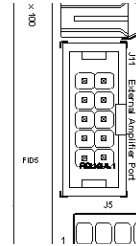

The control pins (Power up and Mute) are connected to the collectors of transistors that can handle 40VDC at 1Amp.

The Diagnostics pin is diode protected so that voltages above +5VDC are blocked from damaging the RXC-3000. The diagnostic input serves to tell the RXC-3000 that the amplifier is working properly. A low voltage on this pin indicates that the amplifier is ok. A high voltage on this pin indicates that the amplifier either has a problem or is not connected.

### External Amplifier Interface

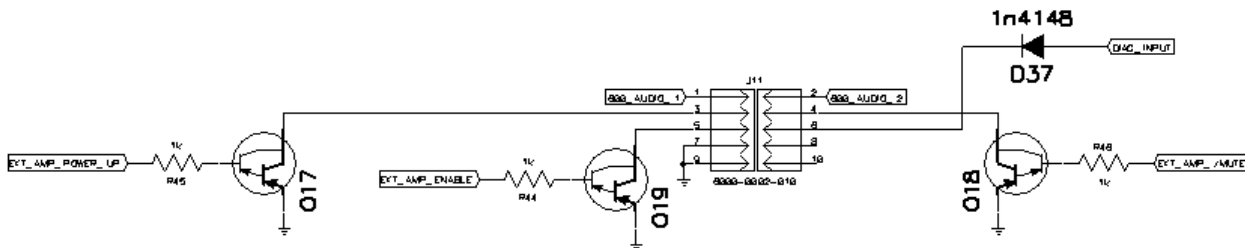

The Audio pins are connected to the 600 Ohm audio transformer. The transformer passes AC voltages but blocks DC voltages from exiting the RXC-3000. The reason for this is to remove “Hum” from the audio lines if the RXC-3000 is not connected to the same power supply as the amplifier.

**Pinout And Characteristics Of 600 Ohm Audio Port**

The 600 Ohm audio port is used to connect the audio from the RXC-3000 to a PA system such as the type used in a school, fire station or office building. Most of these systems have audio inputs that are rated as 600 Ohms of balanced audio (600 ohms between the audio wires and no ground reference).

The transformer passes AC voltages but blocks DC voltages from exiting the RXC-3000. The reason for this is to remove “Hum” from the audio lines if the RXC-3000 is not connected to the same power supply as the amplifier. Additionally, the current sent through the transformer is a push-pull type which allows it to go further without interference from other sources of AC power. Please note that you should use either twisted wires or shielded wires between the RXC-3000 and the PA amplifier. This helps remove unwanted AC signals which cause hum and distortion. Also, do not run the audio wires near fluorescent light fixtures since they produce a large amount of AC noise.

The connector J12 can accept wires up to **16 AWG**.

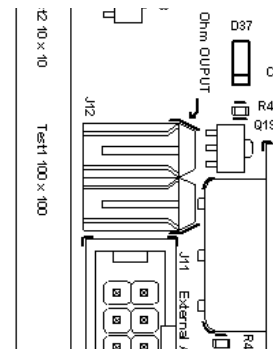

Note: If you connect the 600 Ohm port to a PA system, you cannot use the External Amplifier Control Port since the 600 Ohm transformer is also connected to 2 of the pins in this connector.

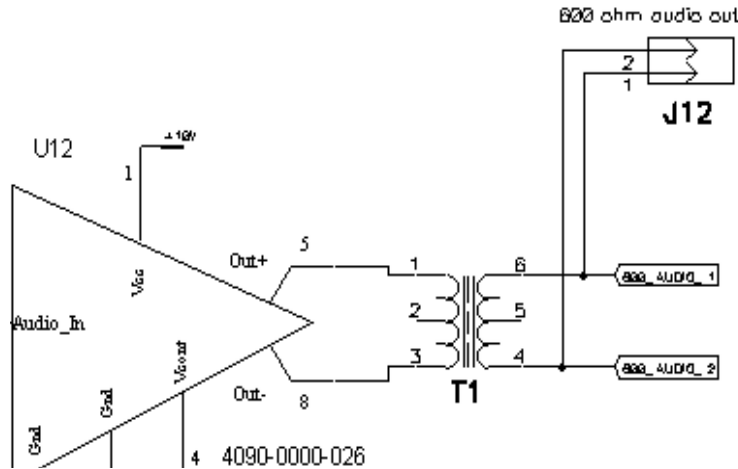

### Setting PA Port Levels

There are 3 voltage controlled amplifiers on the RXC-3000 that boost the audio from the radio and main IC (PWM) and then a final boost into the 600 Ohm transformer. These amplifiers are controlled by R81, R95 and R100 respectively. To set the levels, rotate R100 to half volume then adjust R81 and/or R95 for the desired volume levels individually. If you are using the ADPCM module, you need to set the volume with the potentiometer on the module. Once all of the levels are set, use R100 as the main volume adjustment for setting audio out of the RXC-3000.

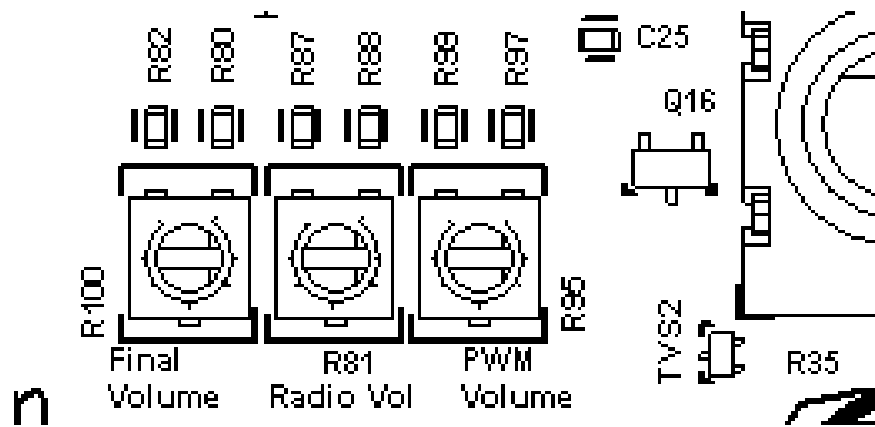

## Radio Port

### Radio Port Pinout

The Radio Interface Port is optimized for use with the Maxon SD series of radios. However, this port can be used to connect the RXC-3000 to any radio or audio source. Here is the pinout of the port:

- |                                |  |
|--------------------------------|--|
| Pin 1 Not Connected            | Pin 8 Push To Talk (/PTT)                      |
| Pin 2 Not Connected            | Pin 9 Not Connected                            |
| Pin 3 Ground                   | Pin 10 Rx Audio From Radio To Decoders         |
| Pin 4 +12 VDC (Fused)          | Pin 11 Carrier Detect (/CD)                    |
| Pin 5 Speaker Audio from Radio | Pin 12 Tx Audio To Radio and Radio Program Pin |
| Pin 6 Ground                   | Pin 13 Programming Data From Radio             |
| Pin 7 Not Connected            | Pin 14 Programming Data To Radio               |

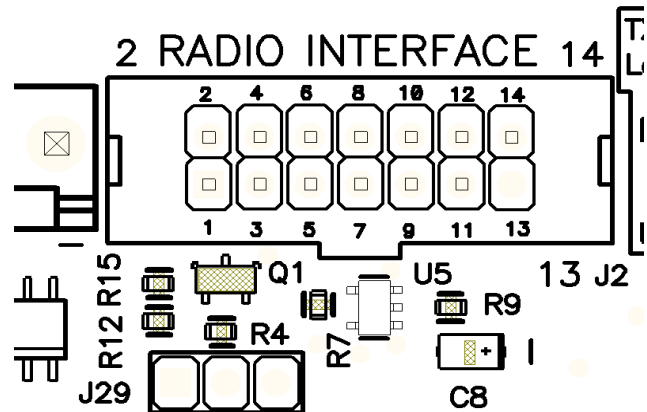

### Radio Power Port

The Radio Power Port (J3) is used to supply power for Maxon SD series radios only. Do not use this port for other types of radios.

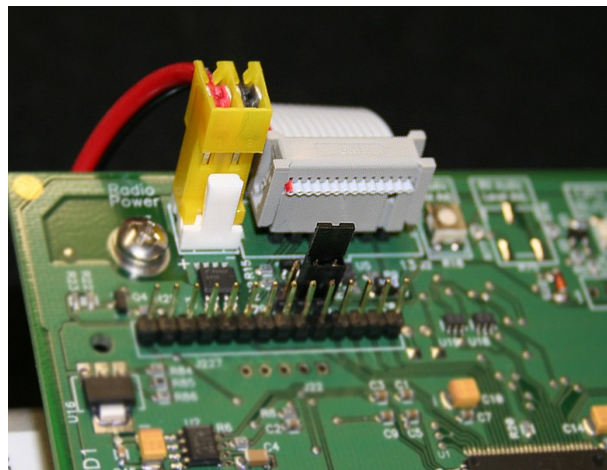

### Setting Rx Audio Levels

The Rx audio from the Radio Port (pin 10) is supplied directly to the high side of potentiometer R75. This pot should be adjusted to provide **100mV to 200mV** of audio on Test Point 1 (just below R75) when receiving 3.0 kc deviation of 1000 Hz in wide band and 1.5 kc deviation in narrow band.

### Setting Tx Audio Levels

The TX potentiometer (R18 ) is driven from a high impedance amplifier. The audio from the TX pot is AC coupled to the Radio Port pin 12. Adjust this pot for **3.0 to 3.5 kc deviation** from the transceiver at Test Point 2 (just below R18). The audio from the ADPCM, DTMF generator and PWM are all summed and amplified for transmission. Please contact Genave for more information.

Radio Interface

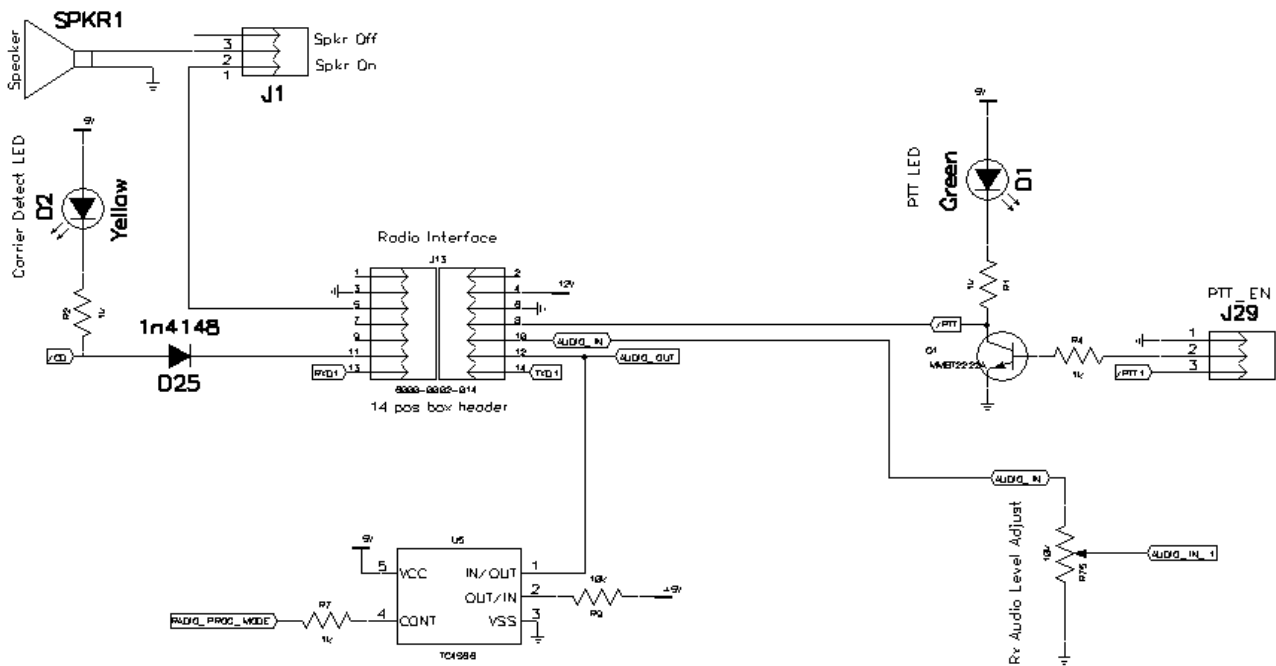

***Radio Audio Levels to PA Port***

*(See Setting PA Port Levels under “PA Audio Port” section of manual)*

***How To Change Frequency (Maxon Radio Only)***

*Please refer to the Programming Guide 9000-0000-041 for more information*

***How To Change DCS/CTCSS (Maxon Radio Only)***

*Please refer to the Programming Guide 9000-0000-041 for more information*

***How To Set Wide/Narrow Bands (Maxon Radio Only)***

*Please refer to the Programming Guide 9000-0000-041 for more information*

***How To Set Squelch (Maxon Radio Only)***

*Please refer to the Programming Guide 9000-0000-041 for more information*

***Returning Radio To Default Settings (Maxon Radio Only)***

*Please refer to the Programming Guide 9000-0000-041 for more information*

## DTMF Decoder

The DTMF decoder circuit listens to the audio signal from the radio for “Touch-Tone” telephone digits. When the digits are discovered, the circuit decodes them and sends to the microprocessor. Mark is the amount of time that a tone is being transmitted and Space is the amount of time that the tone is not being transmitted.

### *DTMF Decoder Characteristics*

The DTMF decoder circuit can accept signals as fast as **18** milliseconds for both Mark and Space timing.

A DTMF string can be anywhere between **2** characters long and **32** characters long.

The decoder circuit requires a gap between character strings of **600** milliseconds to decode the previous string before it can accept another string of characters to decode.

### *Triggering RXC-3000 Off Of A DTMF String*

*Please refer to the Programming Guide 9000-0000-041 for more information*

### *How To Enter/Adjust DTMF Strings*

*Please refer to the Programming Guide 9000-0000-041 for more information*

### *DTMF Learn Mode*

*Please refer to the Programming Guide 9000-0000-041 for more information*

### *“Live Look” (DTMF Digit Grabber)*

*Please refer to the Programming Guide 9000-0000-041 for more information*

## Two Tone Sequential Decoder

### *Two Tone Decoder Characteristics*

The Two Tone decoder is described as a “Non-Predictive” decoder. This means that the decoder is not tuned to look for a specific set of tones. Rather, the unit decodes tones it receives over-the-air and sends the tone information to the main chip where they are compared to a list of tones attached to action scripts.

The Two Tone sequential decoder can detect tones between **210 Hz** and **4000 Hz**.

The decoder is equipped with an Auto-Correlator circuit that acts as a filter to remove all noise from the audio presented to the decoder. Only signals that are periodic (tones) will be passed to the decoder.

When decoding simultaneous multiple tones, the RXC-3000 will only pass along the data on the tone with the greatest amplitude. Hence if the CTCSS or DCS tones are larger than a 1000 Hz tone signal, the decoder chip will not pass data along about the 1000 Hz tone and since the CTCSS and DCS tones are out of the range for the decoder, they are not decoded. The result is that the RXC-3000 does not respond to the signal. As soon as the 1000 Hz signal is increased above the CTCSS or DCS tones, the RXC-3000 will start to display the tone.

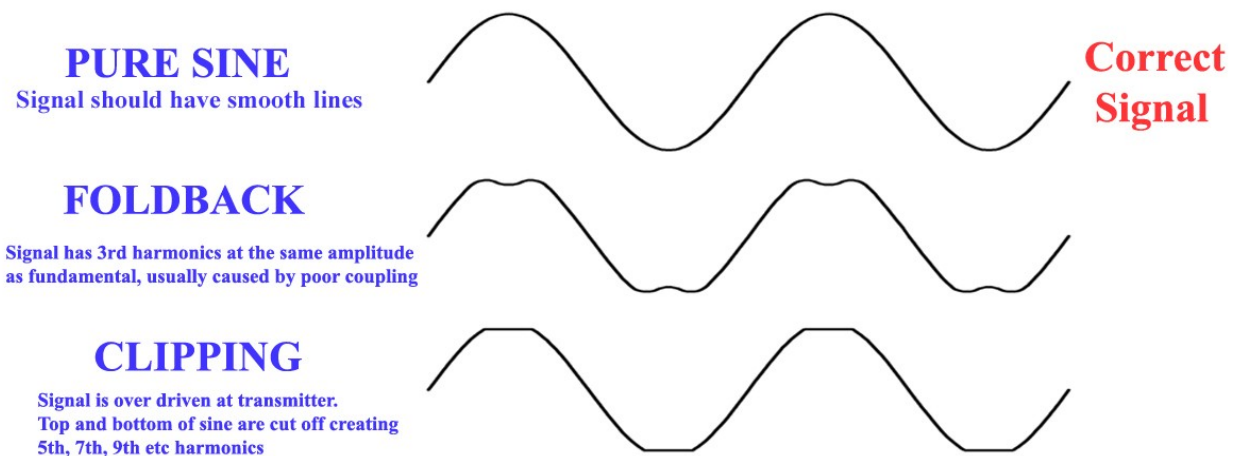

*Illustration 2: Two Tone Sequential Tone Distortion*

It is important to present the RXC-3000 with a clean RF and audio signal from the activation point. If the audio signal is distorted as shown above, the unit will decode the signal, but due to the harmonics riding on the signal, it may not correctly find the frequency of the tone.

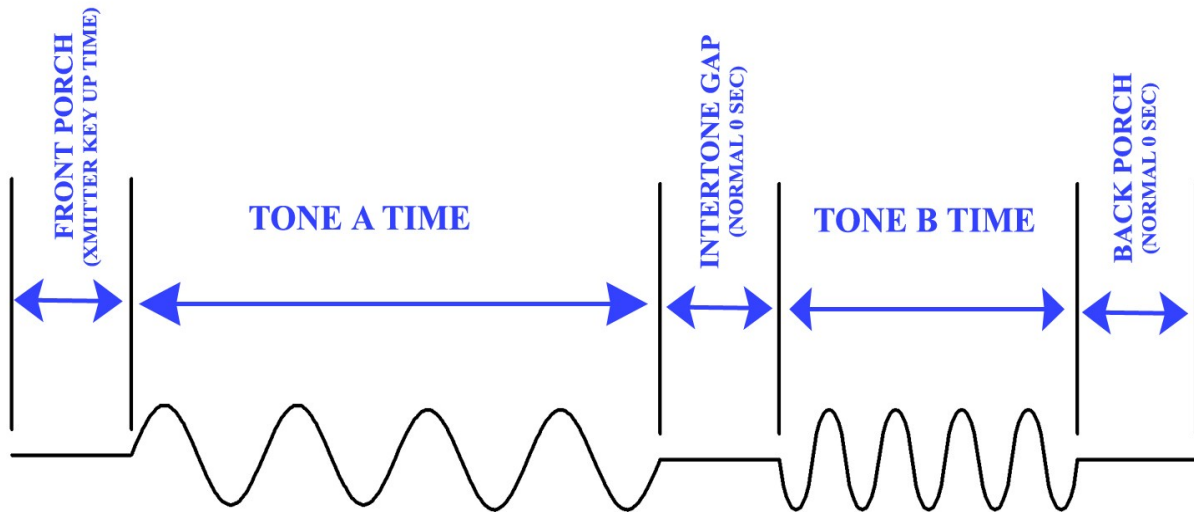

*Illustration 3: Two Tone Sequential Map*

When setting up and programming the RXC-3000 to detect Two Tone Sequential tones, make certain that you have the correct tone frequencies AND the correct tone lengths for both tones. The RXC-3000 has the ability to learn tones over-the-air. However, if the tone lengths vary significantly from the activation point over time or if the tones are generated by hand, the RXC-3000 may not decode them properly.

Here are some reference points for Two Tone sequential tones:

**Front Porch** = Key up time. This is the time required for the transmitter to become stable. This is not a problem with new transmitters, but if the signal is passing through several different pathways to get to the RXC-3000 it may get delayed by up to 250 milliseconds. If not calculated into the A tone time, this would make the A tone too short.

**Tone A Time** = Length of time that the first tone is being transmitted. This time may be as short at 400 milliseconds or as long as 25 seconds.

**Inter-tone Gap** = The amount of time when neither A or B tones are transmitted. Normally this is 0 seconds for most systems. The maximum allowed time for the RXC-3000 is 300 milliseconds

**Tone B Time** = Length of time that the first tone is being transmitted. This time may be as short at 400 milliseconds or as long as 25 seconds.

**Back Porch** = Length of time that the transmitter is still operating but no tones are being transmitted.

**Note:** The Inter-tone Gap is NOT the same as the Inter-sequence gap. This is the time between a set of tones and the next set of tones. The Inter-sequence time is normally 1 second in length to allow decoders time to start working on the first set of tones before another set comes in.

### ***Triggering RXC-3000 Off Of A Two Tone Signal***

*Please refer to the Programming Guide 9000-0000-041 for more information*

### ***How To Enter/Adjust Two Tone Signal Strings***

*Please refer to the Programming Guide 9000-0000-041 for more information*

### ***Two Tone Learn Mode***

*Please refer to the Programming Guide 9000-0000-041 for more information*

### ***“Live Look” (Two Tone Grabber)***

*Please refer to the Programming Guide 9000-0000-041 for more information*

## Real Time Clock

### *Triggering RXC-3000 From The Real Time Clock*

*Please refer to the Programming Guide 9000-0000-041 for more information*

### *How To Adjust Time*

*Please refer to the Programming Guide 9000-0000-041 for more information*

### *How To Set Daylight Savings Dates*

*Please refer to the Programming Guide 9000-0000-041 for more information*

### *Real Time Clock Battery*

The battery for the RTC is a standard 3 Volt CR1612, CR1616, CR1620 or CR1632 battery.

To maintain the current time, replace the battery with power applied to the RXC-3000.

Install the battery into the holder with the negative side to the left and the positive side to the right.

A CR1616 battery will maintain correct time in the clock for up to 3 years.

The CR16XX series of batteries are available at Walmart, Ace Hardware, Radioshack, most pharmacies and most grocery stores.



CR1616 Negative Side



CR1616 Positive Side

## ADPCM Audio Player

### *How Songs Are Played To The PA Port*

When the RXC-3000 runs a script, if it has been told to play a song/sound file, it turns on the ADPCM player and tells the player the file number of the song/sound it is to play. The player automatically selects the file from the TF card and begins playing. At the same time, the RXC-3000 un-mutes the corresponding audio amplifiers and the external PA amplifier circuits.

### *How The RXC-3000 Knows What Songs To Play*

Each song or sound file in the TF card has a specific address. The address starts at 0000.ad4 and can go to 0100.ad4. The very first song file (0000.ad4) is never used. It is simply a place holder in the TF card.

Here is how the memory in the TF card looks like to the RXC-3000:

0000.ad4	Bogus file, never used
0001.ad4	Song #1 (first useable file)
0002.ad4	Song #2
0003.ad4	Song #3
etc.....	
0100.ad4	Song #100 (last useable file)

When the RXC-3000 runs a script, if the text “Play 0006;” is in the script, the RXC-3000 will command the ADPCM unit to play song #6. There are two ways that the song will end or stop. The first way is for the ADPCM to come to the end of the song, at which time it will tell the RXC-3000 that the song is done. The second way is for a new script to have the text “Play 0000;” the RXC-3000 will command the ADPCM module to stop all play functions.

### *Creating ADPCM Files From .mp3, .wav, Etc...*

The ADPCM audio player can only play files that are compressed into a 4 bit ADPCM format (.ad4). Genave supplies a program that converts files from .mp3 and .wav formats into the .ad4 format. Please contact Genave for more information on the conversion program.

### ***TF Card (MicroSD) Characteristics***

All TF cards are not created equal. Use only TF cards manufactured by Sandisk. These cards will play consistently throughout all of the song files. Failure to use Sandisk TF cards may result in loss of audio from the ADPCM module.



### ***How To Program The TF Card***

To a computer, a TF card looks exactly like a USB memory stick or hard drive. Remove the TF card from the RXC-3000 and insert it into a USB TF card reader. Plug the USB reader into a USB port on your computer and the operating system will locate the card and start working with it.

Once you have converted the audio files from mp3 or wave to the .ad4 format, you can copy them directly to the TF card. Put the TF card back into the RXC-3000 and start playing the files.



### ***How To Put A Song Into A Trigger File***

*Please refer to the Programming Guide 9000-0000-041 for more information*

## **Misc**

### ***LCD Display Backlight***

The LCD backlight for the RXC-3000 will automatically turn off to conserve power. All that is required to turn it back on is to rotate the Twist-n-Touch knob.

### ***Heartbeat LED***

The Heartbeat LED flashes once per second to indicate that the RXC-3000 is alive and well. If this LED is not flashing, the unit has either locked up or the power has failed.

### ***Fuse***

The RXC-3000 uses one fuse to supply power to the board and the radio. The fuse type is a fast acting 5mm x 20mm glass fuse, 250V, 2 Amp



# Specifications

## General Specifications

### General

V <sub>SUPPLY</sub> :	90 to 264 VAC, 47 to 63 Hz
I <sub>SUPPLY</sub> :	1 Amps Maximum
Weight:	16 lbs.
Enclosure Size:	11.73 in x 11.73 in x 7.25 in
Enclosure Rating:	NEMA 4X, Polycarbonate
Power Connector:	3 Terminals, #6 screw
Temperature: Run	-30° to +80° C
Temperature: LCD	-10° to +50° C

### Inputs

Number:	8, Logic level active low,
Vin:	Internal pull-up, 5vdc max
Debounce:	150 msec
t <sub>SCAN</sub> :	< 2 msec

### Relay Outputs

Number:	Up to 5
V max:	230 vac
I max:	7 amps
Type:	1 Form C

### LCD

Width:	1 to 16 char.
Lines:	2
Font:	5 x 7

### RF Transceiver

Model:	Maxon SD-161/171/164/174
Freq Range:	148 MHz to 174MHz 450 MHz to 490MHz
Specs:	See Maxon manual for more details

### Communication

Format	USB 2.0
Software	Use Genave ComstarG3™ software

### DTMF Decode

Mark <sub>MIN</sub> :	18 msec
Space <sub>MIN</sub> :	18 msec
Sensitivity:	200 mv p-p, min 3 Vp-p, max
Twist <sub>MAX</sub> :	+/- 8 dB
Interword:	0 to 25.5 sec
Length:	32 char. max

### Tone Decode (optional)

Accuracy:	> 0.2%
Selectivity, adj.:	0 to 4000 Hz
Range:	210 – 4000 Hz
S/N Ratio:	0 dB or better
Detect <sub>MIN</sub> :	400 msec
Detect <sub>MAX</sub> :	25.5 seconds
Intertone <sub>MAX</sub> :	300 msec

### Number of Two Tone seq. A/B tones decoded

20

