

Example wiring method to control heavy loads with the RXC-2000

RXC-2000

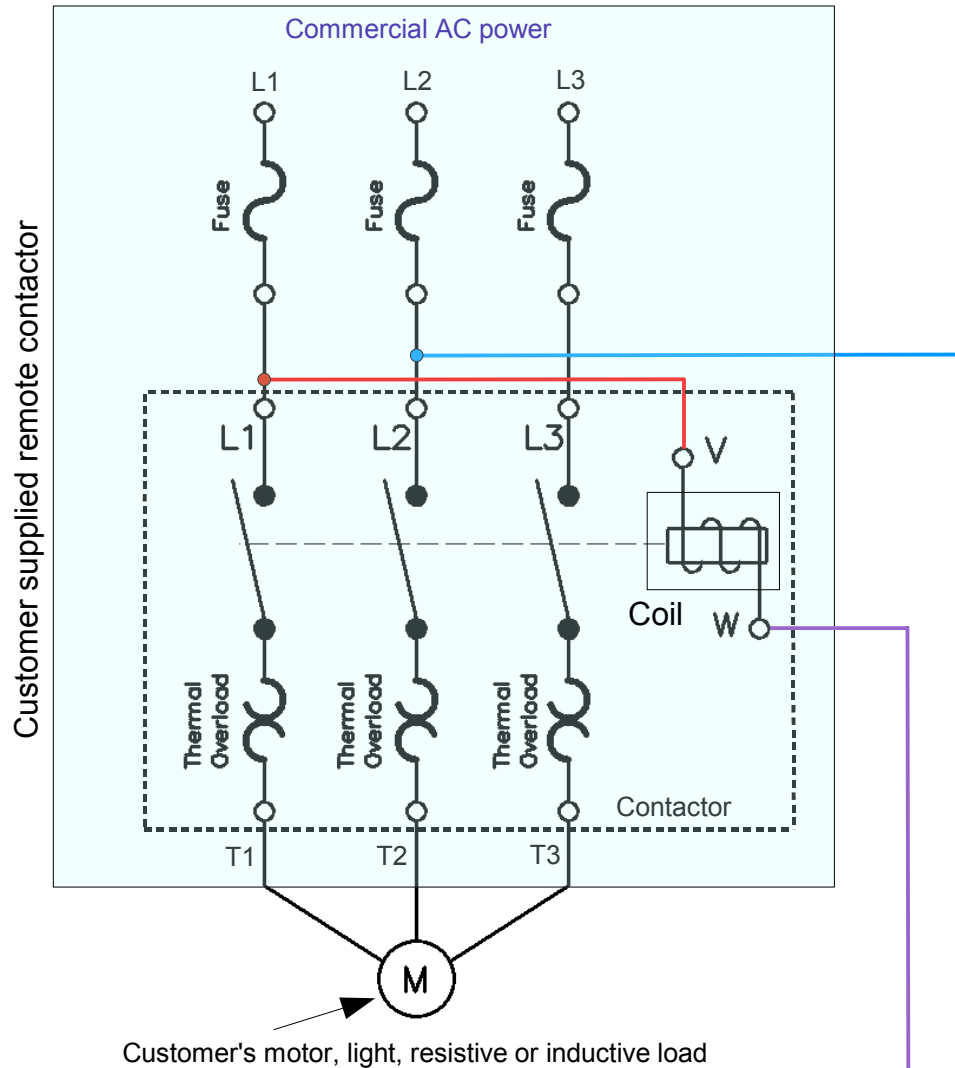

In this example, when relay #1 on the RXC processes the radio command to engage, it completes the coil circuit of the contactor. The contactor then turns on and lets the voltage flow to the customer's device.

Turn off ALL power before working on any electrical equipment. Follow all applicable electrical and safety rules and regulations. This is only an example. Your contactor and wiring may differ. Electrical work should only be performed by licensed and qualified personnel.

